

AUDIOPHILE ACOUSTICS

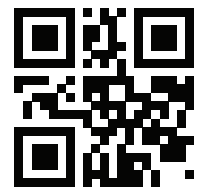

B2[®]

SWEET LIKE DANISH

Zero 9

USER MANUAL

PRODUCT ID:

Z9022

WWW.B2AUDIO.COM / WWW.FACEBOOK.COM/B2AUDIO



INTRODUCTION

The introduction of the Zero amps was more than a decade ago. All built by the same concept, efficiency, power & control and stability! 2018/2019 the line expanded with the Zero Five and the Zero 8. Both gamechangers, however the Zero 8 really cemented its place. The 2022 model was supposed to be a refinement of the initial Zero 8, but.....

The result was a model change to Zero 9 as we went back to the drawing board. The circuit was entirely redesigned, opting for increased performance, improved & efficient cooling system modes, as well as simple gain matching features. Thus, this amp was just too different for simply naming it the same as the Zero 8, even though performance is at least on par!

Zero 9

Reviving the Zero's.

These amplifiers set multiple world records and have secured championships all over the world. In their time the Zero line was the benchmark to compare with. Not only in terms of performance, but even appearance. We decided to merge the DNA and heritage of the Zero series amplifiers, but to build with the technology of the future. Our previous amplifiers have been noted as world's first and created a demand for how future amps should be equipped. The Zero 9 follows in the footsteps of our previous models. These amplifiers are not meant to be the most powerful on the market. They are a statement of quality both in design and in the components used. Sourced from all over the world and not accepting anything other than the best, they boast amazing power ratings, but offer reliability and a sense of pride in ownership, rarely seen in this era. Unique features combined with proprietary designs will keep them ahead of the game, offering an advantage which will show the true value of the product.

To obtain the full potential of any amplifier & to minimize failure, it is advised to upgrade your stock electrical system. Don't take any shortcuts, a better electrical equals enhanced performance and stability.



AUDIOPHILE ACOUSTICS

IS THE CORNERSTONE OF B2 AUDIO. IT'S THE PHILOSOPHY OF ADDING SOMETHING UNIQUE. KEEP IN MIND THAT CONTINUOUS EXPOSURE TO SPL ABOVE 100 DB CAN SERIOUSLY DAMAGE YOUR HEARING. TODAY'S HIGH POWER AUTO SOUND SYSTEMS CAN EASILY PRODUCE SPL OVER 140 DB. ENJOY YOUR MUSIC WITH SENSE.

TABLE OF CONTENTS

DESIGN FEATURES	3	SPEAKER CONNECTION	7
PANEL LAYOUT	4	MASTER/DAISY LINKED MODE	8
POWER TERMINAL	5	ACCU8 CROSSOVER & BOOST	9
INSTALLATION & PREPARATION	6	TROUBLESHOOTING	10
		WARRANTY INFO	11

DESIGN FEATURES

CIRCUIT CONFIGURATION:
FREQUENCY RESPONSE:
SIGNAL TO NOISE RATIO:
INPUT SENSITIVITY:
CROSSOVER CIRCUIT:
LOW PASS CROSSOVER:
SUBSONIC CROSSOVER:
PHASE:
DAMPING FACTOR:
REMOTE CONTROL W/CLIP & VOLTMETER:
POWER TERMINAL GAUGE
FUSE RATING:
DIMENSIONS:

Zero 9
HI-EF CLASS D
10 HZ ~ 300 HZ
>95 DB
5 V ~ 0.2 V
24 DB / OCT
35 HZ ~ 250 KHZ
10 HZ ~ 50 HZ
0 ~ 180
>400
⊕
0 GA X 4
800 A
23.62 X 12.4 X 2.95" / 60 X 31.5 X 7.5 CM

All features are subject to change in the continuing effort to improve the products without notice.

CONTINUOUS OUTPUT POWER (RMS)

MEASURED @ <1% THD (40 HZ) USING AUDIO PRECISION

	12 V < 1% THD	13.8 V < 1% THD	14.4 V < 1% THD	16 V < 1% THD
OUTPUT POWER @ 4 Ω:	2200 W	3000 W	3400 W	3500 W
OUTPUT POWER @ 2 Ω:	3800 W	5500 W	5900 W	6000 W
OUTPUT POWER @ 1 Ω:	6000 W	8000 W	8500 W	9000 W

DESCRIPTIONS OF SPECIFICATIONS

OPERATION BELOW MINIMUM IMPEDANCE WILL STRESS THE AMPLIFIER & VOID THE WARRANTY. EXCESSIVE HEAT WILL OCCUR, CAUSING THE AMPLIFIER TO GO INTO THERMAL PROTECTION. THE CIRCUIT MAY SUSTAIN PERMANENT DAMAGE AND PROTECTION LIGHTS WON'T TURN OFF OR FLASH SEQUENTIALLY. OPERATIONAL VOLTAGE IS FROM 9V TO 17.5V

PROTECTION MAY ALSO BE CAUSED BY THE FOLLOWING

- *INPUT VOLTAGE FROM HEADUNIT BEING TOO HIGH / LOW / POWER SUPPLY VOLTAGE TOO HIGH / LOW.
- *SPEAKER OVERLOAD
- *SHORT CIRCUIT

*FULL OUTPUT POWER ACCORDING TO THE SPEC IS BASED ON A SUFFICIENT ELECTRICAL SUPPLY SYSTEM. IF YOUR SYSTEM IS INADEQUATE, THE EFFICIENCY OF THE AMPLIFIER DECREASES HURTING THE PERFORMANCE!

THE ZERO 9 WILL NEED A DEDICATED AGM BATTERY OF MIN 500 AH AND 2000 CCA. IF YOU ARE USING A COMMON LITHIUM SOURCE OF 6C, A 150 AH LITHIUM BATTERY WILL SUFFICE.

PANEL LAYOUT

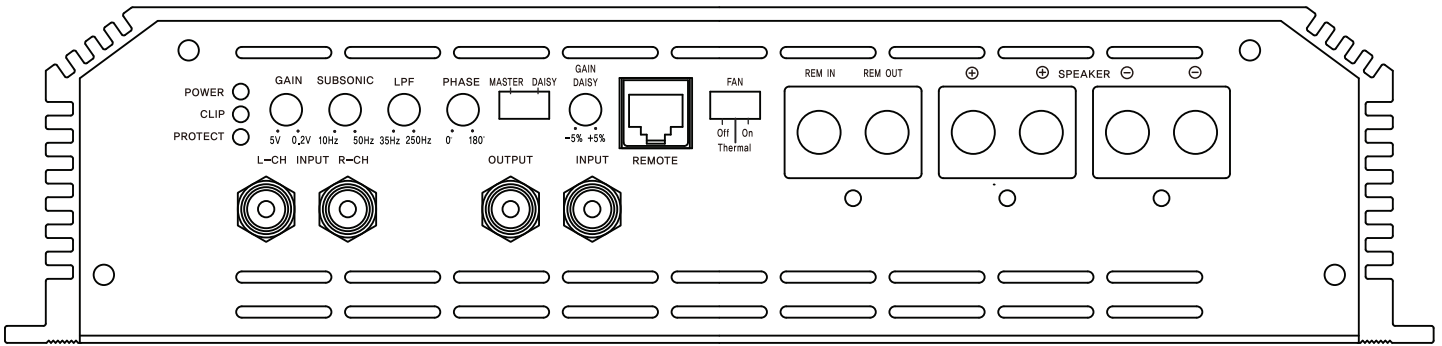

INPUT

RCA signal input for left & right channel.
A minimum of 0.2V input signal is required for correct operation. Using only 1 input will minimize input signal and amplifier will need to be gained as such.

POWER & PROTECTION INDICATOR

Power LED, blue light shows correct operation,
Protect LED, red light shows general malfunction, faulty connection or thermal protection.

CLIP INDICATOR

The LED will light up if signal is clipped. An occasional flashing light is acceptable, a constant lit diode is not.

GAIN (5V-0.2V)

Adjusts signal input voltage from the input source to match the amplifiers input stage.
0.2V ~ 5V is the operational voltage.
Voltages beyond may cause errors or damage to the input section.

SUBSONIC

Variable subsonic setting from 10 Hz to 50 Hz.
It is highly recommended to set it according to the tuning of your subwoofer enclosure to avoid unnecessary strain to your sound system.

LPF (LOW PASS FILTER 20 HZ -200 HZ, 24 DB/OCT)

Adjusts the cut off point for the low pass crossover at the frequency chosen.

PHASE

Variable phase adjustment from 0 ~ 180°
adjusted in accordance with the amplifiers gain.

MASTER / DAISY

Master & Daisy switch for daisy chain link or master mode.
In daisy, the master amplifier will route the gained signal to daisy (linked) amplifier. The gain on the daisy is controlled the master.

GAIN DAISY

Fine tuning of the master signal routed to the daisy amp.
While the ordinary gain on daisy amps are disabled, the daisy amp is gain matched by the master, but if there is a slight variance in signal up to +/- 5%, the Daisy gain can equalize it.

REMOTE

Remote level control port with clip and voltage output.

FAN

Switch selection of the internal fans operational mode.
Off turns of the fan entirely. Thermal mode will have the fans kick in at set temperature. On is continuous mode

REM IN / REM OUT

REM IN = Switched remote signal to turn on the amplifier.
REM OUT = Switched remote signal output. This can be used for daisy amps or other 12V equipment.

POWER TERMINALS

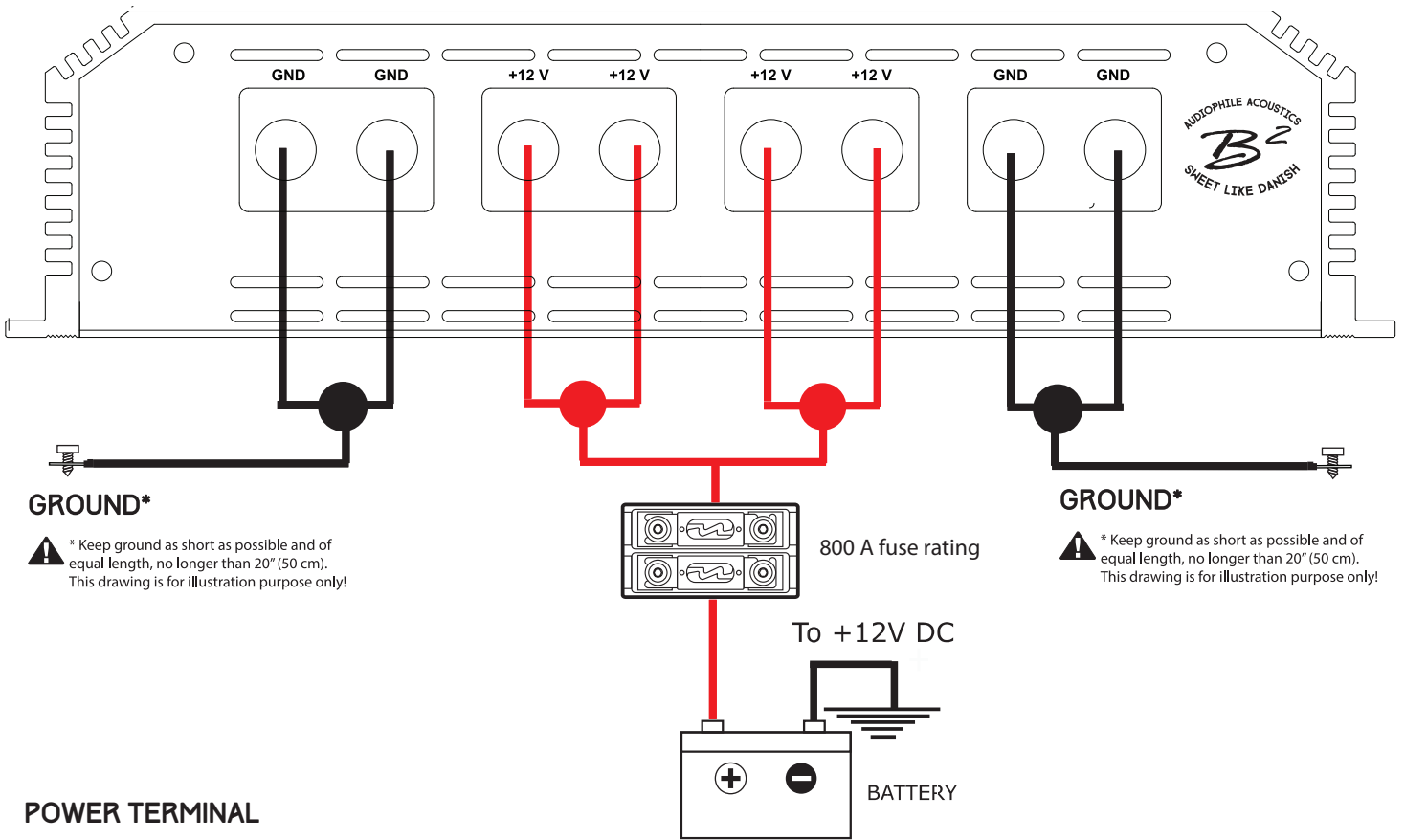

GROUND*

⚠ * Keep ground as short as possible and of equal length, no longer than 20" (50 cm). This drawing is for illustration purpose only!

GROUND*

⚠ * Keep ground as short as possible and of equal length, no longer than 20" (50 cm). This drawing is for illustration purpose only!

POWER TERMINAL

GND (GROUND CONNECTION)

Connects to the vehicle's chassis. Keep as short as possible (< 20" / 50 cm). Use minimum 0AWG cable for optimal operation.

+12V (POWER CONNECTION)

Connects to the positive terminal of the battery. For specified performance 0AWG cable is required. Fuses shall be placed within 8" / 20 cm of the battery.

⚠ CAUTION

INSTALLATION OF THE AMPLIFIER SHALL BE DONE IN THE FOLLOWING STEPS:

1. Connect the +12V wire, keep in mind this wire has to be fused at the battery as well.
2. Ensure the ground is appropriate, then connect it to the amplifier.
3. Connect the switched remote.
4. Reattach negative wire (ground) to the battery.
5. Operation over 17.5V will cause the amplifier to go into protect & can void the warranty!

B² audio

INSTALLATION

INSTALLATION CONSIDERATIONS

If you choose to install the amplifier by yourself, please read the entire owner's manual carefully. Before you start your installation, please take all steps into consideration. If in doubt, please go to www.b2audio.com for authorized distributors / dealers that will be able to configure your set up & ensure the warranty of your amplifier.

PREPARATION

Disconnect the negative (-) battery cable before mounting or making any connection. Check the battery & alternator ground (-) connection. Make sure they are properly connected/dimensioned & free of corrosion. Before selecting a mounting location for the amplifier, please take cooling & safety into consideration. Avoid areas with excessive vibration & up side down installation!

In order to avoid excessive heat from the amplifier, it is recommended to find a mounting location that allows for vertical positioning of the heatsink fins. For safety purposes, install the amplifier in a dry and well ventilated location and make sure no cables or other harness of the car is interfaced with the mounting location or will present a hazard to the car's cable, control cables, fuel lines/tanks, hydraulic lines or other components of the vehicle. Route the RCA cables away from high current wires, if possible run RCA, Power and Speaker cables individually and with a good distance from each other.

POWER CONNECTORS

12V (POWER CONNECTION)

Before mounting the amplifier, disconnect the negative (-) wire from the battery to protect any accidental damage to the amplifier or the audio system. The amplifier is equipped with quad 0 AWG power & ground terminals. It is crucial that all terminals are used with the adequate cable to ensure correct operation. Connect the power cables to the power terminal labeled as +12V.

The amplifier is not equipped with fuses, so external fuses are required at both the battery and the amplifier. Connect one end of the fuse holder to the power cable and the other end of the fuse holder to the positive battery terminal within 8" / 20 cm of the same cable. The same shall be done at the other end of the cable that connects to the amplifier. The fuses will protect the system and the vehicle against the possibility of a short circuit in the power cable. Make sure that the fuses and the fuse holder is according to the system requirements.

GND (GROUND CONNECTION)

Locate a secure grounding connection as close as possible to the amplifier. Make sure the location is clean and provides a direct electrical connection to the chassis of the vehicle. Connect one end of an equal sized cable as the positive cable to the location of ground. It is important that the ground cable is as short as possible, but no longer than 20" / 50 cm at maximum. Run one end of the cable to the grounding point. Run the other end of the cable to the mounting location. Connect the ground cable to the terminals labeled as GND.

REM (REMOTE CONNECTION)

Run a remote turn on cable from the switched +12 V source. This may be a toggle switch, a relay, the source unit's remote output cable or power antenna trigger cable. Connect the remote turn on cable to the power terminal labeled as REM. The REM out terminal is mainly intended for connection of another amplifier ran in a chain, but it can also be used for other units.

INPUT (RCA CABLE)

Run the RCA cables away from the high current cables / speaker cables and connect to the amplifier. Use high quality cables with a secure grounding point to avoid amplifier malfunction and / or alternator whine.

B² audio

SPEAKER CONNECTION

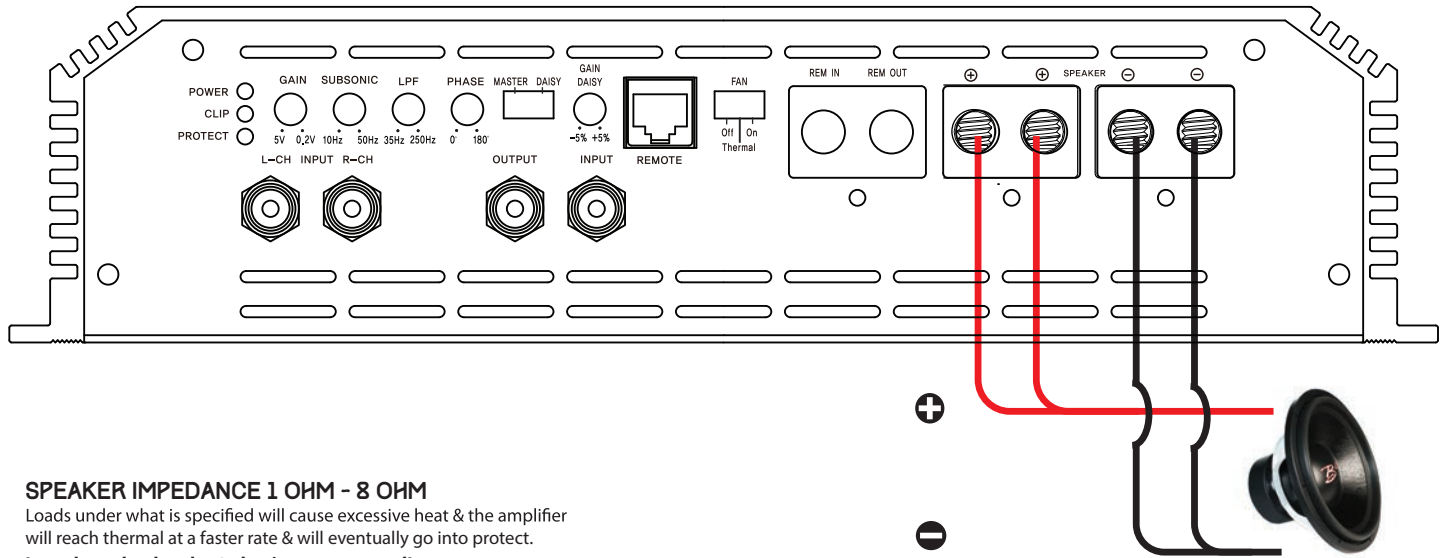

SPEAKER IMPEDANCE 1 OHM - 8 OHM

Loads under what is specified will cause excessive heat & the amplifier will reach thermal at a faster rate & will eventually go into protect.

Impedance load under 1 ohm is not warranted!

We recommend using minimum 8 Ga speaker cables to acquire the intended performance & efficiency. Run the speaker cables from your speakers to the amplifier's mounting location. Ensure these are ran separately and away from high current cables and if possible the RCA cables as well. In all cases where cables are penetrating the vehicle's chassis use grommets to protect the cable.

Connect the speaker wires according to the terminals on the speaker(s). Strip 3/8" / 1 cm of insulation of the end of each cable and twist the cable strands together tightly. Make sure there are no stray strands that could touch other cables or terminals as it can cause a short circuit.

Crimp spade plugs over the end of the cable or tin the ends with solder to provide a solid terminal.

Connect the cable ends to the amplifier as shown in the diagram. Note, the amplifier's speaker terminals are internally bridged.

CAUTION

INSTALLATION OF THE AMPLIFIER SHALL BE DONE IN THE FOLLOWING STEPS:

1. Connect the +12V wire, keep in mind this wire has to be fused at the battery as well.
2. Ensure the ground is appropriate, then connect it to the amplifier.
3. Connect the switched remote.
4. Reattach negative wire (ground) to the battery.
5. Operation over 17.5V will cause the amplifier to go into protect & can void the warranty!

B² audio

DAISY CONTROL PANEL SETTING / SPEAKER WIRING

MASTER

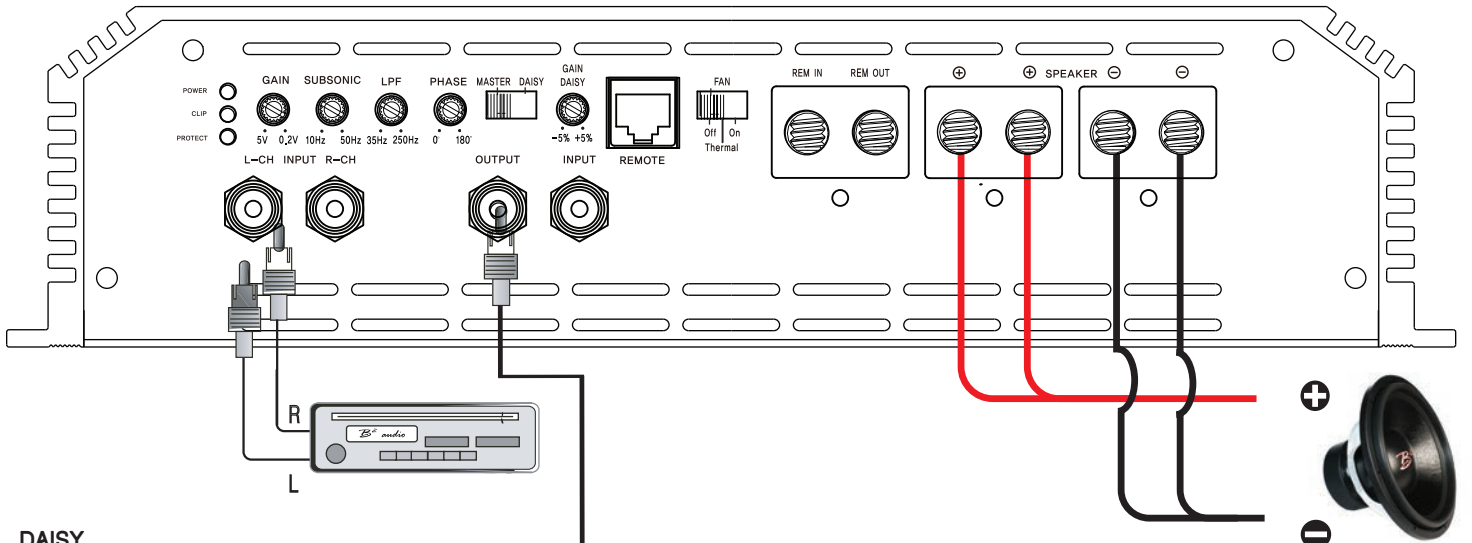

DAISY

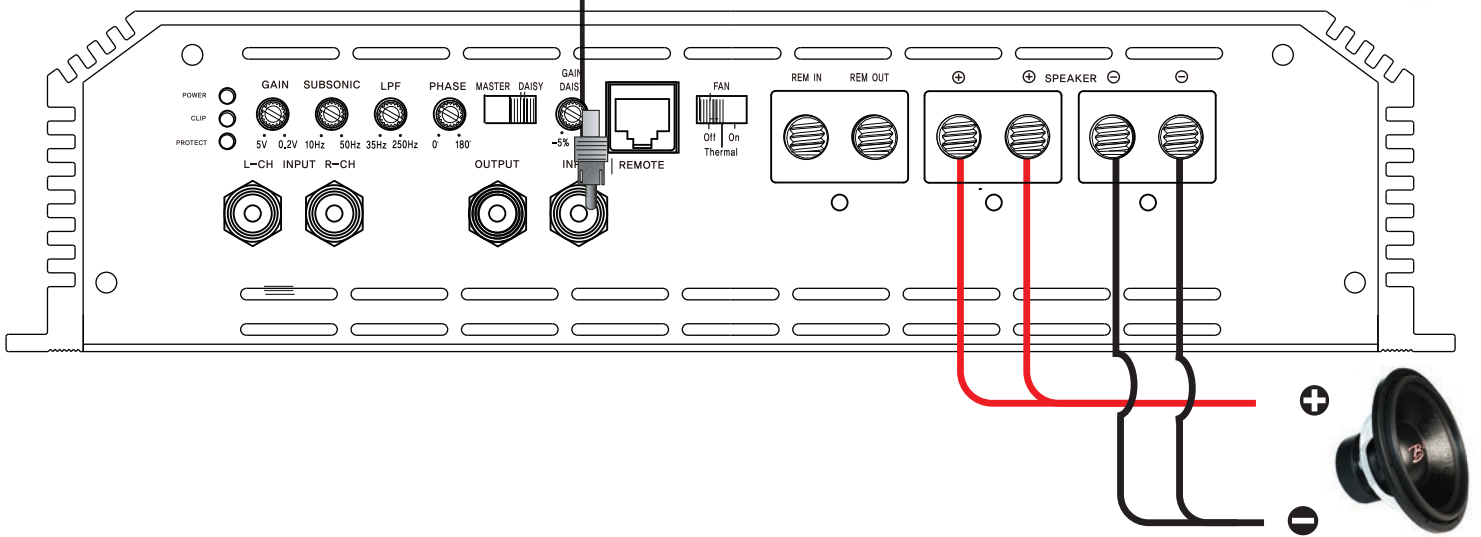

B² audio

ACCU8 CROSSOVER

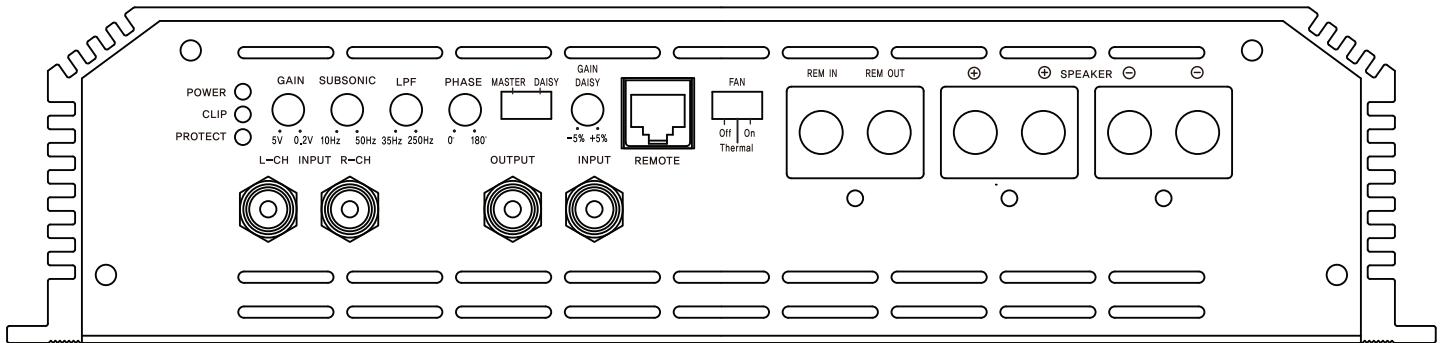

LOW PASS.

The low pass crossover is 24 dB / oct. Setting it at 80 Hz will have the signal attenuated with 24 dB at 40 Hz (1 octave). To ensure accuracy for the individual crossover frequency the pot feature 41 clicks, each with a corresponding frequency. The same is valid for the bass boost settings, which also features 41 clicks. We call this feature for ACCU8.

CLICK SETTINGS FOR LPF

LPF	LPF	LPF
1. 33 Hz	15. 61 Hz	29. 160 Hz
2. 34 Hz	16. 68 Hz	30. 170 Hz
3. 34 Hz	17. 76 Hz	31. 181 Hz
4. 35 Hz	18. 86 Hz	32. 185 Hz
5. 35 Hz	19. 100 Hz	33. 190 Hz
6. 36 Hz	20. 111 Hz	34. 195 Hz
7. 36 Hz	21. 116 Hz	35. 200 Hz
8. 39 Hz	22. 120 Hz	36. 203 Hz
9. 41 Hz	23. 125 Hz	37. 207 Hz
10. 43 Hz	24. 130 Hz	38. 210 Hz
11. 46 Hz	25. 135 Hz	39. 230 Hz
12. 50 Hz	26. 140 Hz	40. 240 Hz
13. 55 Hz	27. 144 Hz	41. 250 Hz
14. 57 Hz	28. 151 Hz	

B² audio

TROUBLESHOOTING

The protection circuits of the amplifier prevents severe damages from faulty conditions & improper use. The protection indicator will switch on due to short circuit connection & speaker overload, thus the amplifier will be turned off. Prior to inspecting the occurred problem, turn all levels down & all power off, then carefully check the installation for wiring mistakes, shorts or faulty ground (GND). If the amplifier shuts down due to excessive heat, the protection indicator will light up; please allow time for the unit to be cooled off. Before removing your amplifier, refer to the list below and follow the suggested procedures step by step. If not at ease, contact an authorized installer which can assist you.

AMPLIFIER DOESN'T TURN ON

- Measure voltage on the +12V terminal.
- Ensure that the remote terminal has min. 13.8 V DC remote connection.
- Recheck the ground (GND) connection. Inspect the in-line fuses.
- Check the protection LED is not on.

PROTECTION LED IS LIT ONCE THE AMPLIFIER IS TURNED ON

- Check shorts on speaker wires & the connected load / impedance. Check power cables & GND.
- Disconnect the speaker cables and reset the amplifier.
- High / Low voltage, operation voltage is 9V~17.5V. Voltages below / beyond this will cause the amplifier to go into protect.

FUSE BLOWING

- Measure the speaker impedance & that it is in accordance with the configuration.
- Inspect the power cable for shorts along with vehicle chassis.

OVERHEATING

- Measure the speaker impedance & that it is in accordance with the configuration.
- Check speaker shorts.
- Ensure airflow around the amplifier is sufficient & that the amplifier is not installed in areas of excessive vibration & upside down!

AUDIO OUTPUT INSUFFICIENT - DISTORTED SOUND

- Ensure that the gain settings on the amplifier is matched with the output level of the head unit.
- Adjust the head unit volume.
- Check speaker shorts.
- Adjust the crossover frequencies in accordance with the setup.
- If no output at all, check the RCA connections & the cable itself.

TURN ON THUMP

- Disconnect the signal input to the amplifier, then turn it on and off.
 - a) If the noise is cancelled, then connect a delay turn on module on the REM wire running from the source unit to the amplifier.
 - b) Use another 12V source for REM lead to the amplifier. If the noise is cancelled, use a relay to isolate the amplifier from the turn on thump.

HIGH HISS-ENGINE NOISE IN SPEAKERS

- Ensure that all signal transferring wires (RCA, speaker cables etc) are kept separately / away from the power and the ground wires.
- Bypass all electrical components between the Head unit and the amplifier.
Connect the Head unit directly to the amplifier's input. If the noise is eliminated, the unit bypassed is the one causing the noise.
- Remove the existing ground wires for all electrical components installed. Ensure that the point of ground is 100% metal which has been grinded free of rust, paint etc.
- Replace the ground cable from the OEM battery / alternator and ensure it is grounded accordingly.
- Test the battery and alternator load (can be carried out by a professional).
Ensure that the vehicle's electrical system is in a good condition, this includes distributor, alternator, spark plugs / wires, voltage regulators etc.

B² audio

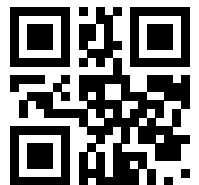

AUDIOPHILE ACOUSTICS

B2[®]

SWEET LIKE DANISH

LIMITED WARRANTY INFORMATION

B2 audio offers a limited warranty under the following terms:

The product is to be free of defects in material & workmanship under normal use for a period of 1 year from the date of the original purchase, when installed by an authorized dealer. Items not installed by authorized dealers will be warranted for 30 days from the original purchase. Original sales receipts must be accompanied with all returns. The warranty applies to the original purchaser of the product & it being sold by authorized B2 audio dealers.

- The warranty does not cover:
1. Damage caused by accident, abuse, misuse, improper operation, water / solvents & shipping.
 2. Product modification, neglect, failure to follow installation instructions & misrepresentation by the seller.
 3. Products used for competition purposes or are of such a character 4. Any product that has been opened.
 5. Products that has had the serial number defaced, altered or removed.
 6. The cost of shipping the product back for repair to an authorized repair centre & cost of return of non-defective items.

